



TENSIONER³

SINGLE HANDED CURTAINSIDER TENSIONING

**At last ...
a curtain tensioner
that is efficient
and simple to use**



STRUCTURFLEX
INNOVATION - DESIGN - QUALITY

TENSIONER³

Patent No's
 NZ239486
 AU665201
 UK2258805

Fit to both ends of each Flexisider Curtain
 for maximum convenience and efficiency

ALLOY HOUSING

Provides a lightweight body that has been designed with extra reinforcing in the high stress areas.

HIGH TENSILE STEEL SHAFT

The Clevis is cut to match the cast alloy base plug in the Structurflex Anodised Aluminium luff groove pole, providing both high strength and ease of use.

NYLATRON BUSH

Molybdenum disulphide impregnated nylon bush provides a self lubricating bearing.

ALLOY HANDLE

Cast in high tensile alloy provides two bearing surfaces on the nylon bush and retracts to lock away flush with the body.

RELEASE TRIGGER

This provides a one hand operation by holding the trigger and pulling the handle right back which releases the shaft allowing the curtain to spring out so the pole can be immediately disengaged.

PRECISION INVESTMENT CAST SPROCKET AND PAWL

Utilises high carbon steel for strength and for wear resistance.

ROLLED THREADS

All threads are rolled threads which increases the thread strength by 30 percent.

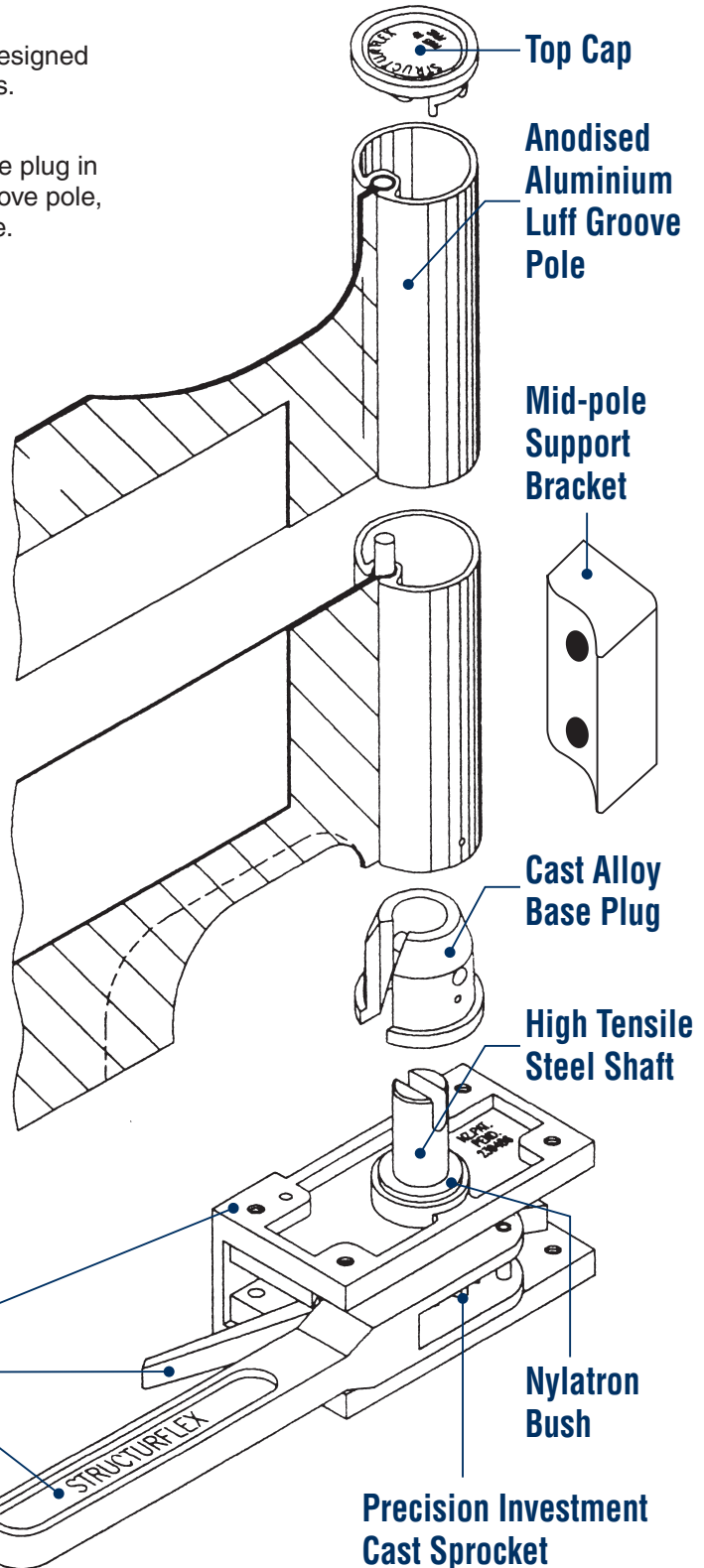

TENSIONER³ (ACW & CW)			
Dimensions (mm)			
	Length	Width	Height
Small Body	100	75	65
Large Body	140	75	65

Alloy Housing

Release Trigger

Alloy Handle

Nylatron Bush

Precision Investment Cast Sprocket



STRUCTURFLEX

101 Central Park Drive, Henderson, Auckland, New Zealand
 Private Bag 93 113 Phone 64 9 837 2350 Fax 64 9 837 2354
 Email info@structurflex.co.nz Website www.structurflex.co.nz